

NOTES

The inlet and outlet seals are Polylok Poly II High Pressure Pipe Seals.

Concrete Inlet Riser Sold Separately.

Tank walls are 3" thick and the floor is 4" thick.

Total Weight: 6,800 LBS

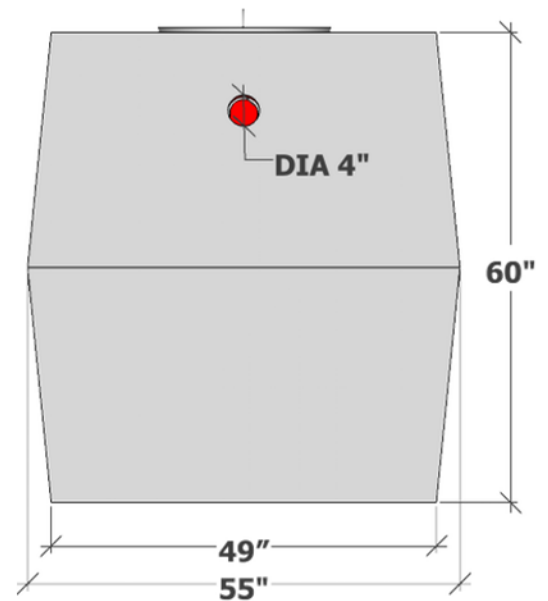

TITLE

750 Gallon Pump Chamber

DATE 10/24/17

REVISION 1.0

THE FAGENSTROM CO.

2101 NORTHWEST BYPASS

P.O. Box 2623

GREAT FALLS, MT 59403

WWW.FAGENSTROM.CO

406-761-5200

